

INSTRUCTIONS AND OPERATING NOTES

REFLECTOMETER

MODEL 369A

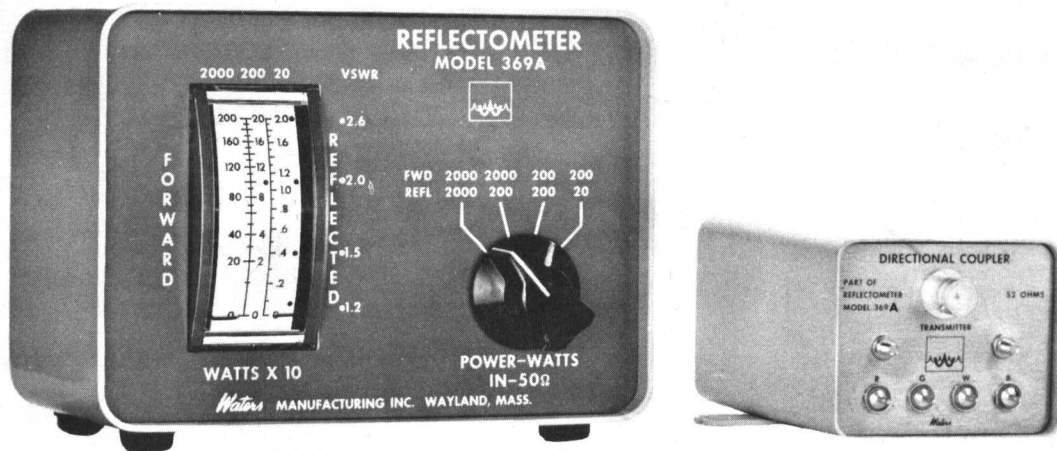

Waters **MANUFACTURING, INC.**
WAYLAND, MASSACHUSETTS,

SPECIFICATIONS

Frequency Range:	3.5 to 30 MHz	
Impedance:	50 ohms nominal	
Power Ranges:	<u>Forward</u>	<u>Reflected</u>
	2000 watts	2000 watts
	2000 watts	200 watts
	200 watts	200 watts
	200 watts	20 watts
Power Accuracy:	±10%, full scale	
Maximum Power Handling Capacity:	2000 watts Forward Power, continuous	
Power Loss Through Coupler:	Negligible	
Residual VSWR:	Less than 1.06	
Connectors:	BNC (UG-1094/U) Mates with BNC (UG 88/U) (Adapters, BNC to UHF, furnished)	
Connecting Cable:	Belden 8445	
Size:	Indicator:	5 1/2 x 3 3/4 x 4 1/4 in.
	Directional Coupler:	4 x 2 x 2 7/16 in.
Weight:	Indicator:	1 1/2 lbs.
	Directional Coupler:	3/4 lbs.

REFLECTOMETER

MODEL 369A

OPERATING INSTRUCTIONS

DESCRIPTION

The WATERS Model 369A REFLECTOMETER is a dual indicator voltage standing wave ratio measuring instrument for use with high frequency radio transmitters (3.5 - 30 MHz) to measure and indicate the impedance match between the RF transmission line and the antenna. Since the Model 369A REFLECTOMETER is equipped with a dual indicating meter, both the Forward and Reflected Power readings are displayed simultaneously. The power scales are directly calibrated in RF watts (at 50 ohms impedance), thus the REFLECTOMETER, in conjunction with a good 50 ohm Dummy Load, is also an accurate RF Wattmeter.

In most applications of VSWR measurements, the user is primarily interested in readings approaching a 1:1 ratio. The Model 369A REFLECTOMETER, unlike most other equipments, provides a multiple choice of power scales which, in effect, increase the Reflected Power reading sensitivity by 10 times, thus permitting accurate determination of VSWR as low as 1.1:1. Single scale VSWR instruments simply cannot approach this low value with significant accuracy.

The Model 369A REFLECTOMETER consists of two separate units, connected by a five conductor cable. The Indicator contains a dual movement power meter and range selector. The Directional Coupler is designed to be mounted remotely as the transmitter RF output terminal in series with a 50 ohm coaxial transmission line. Terminals on the Directional Coupler are BNC type (UG-1094/U), and two BNC to UHF adapters are furnished to permit use with the popular PL-259 connectors. For use with other types of connectors, standard in-line adapters are available commercially. No external power is required to operate the REFLECTOMETER, and its insertion loss is negligible.

MATERIAL PROVIDED

- 1) Reflectometer Indicator and Directional Coupler
- 2) Interconnecting Cable - 10 feet of Belden 8445
- 3) 4 pieces of heat shrinkable tubing
- 4) 4 contact pins
- 5) 2 cable clamps and 2 washers
- 6) 1 6-32 binder head screw
- 7) 6 #6 solder lugs (fork tongue)
- 8) 2 #6 lockwashers
- 9) 2 6-32 hex nuts
- 10) 2 UG-255/U BNC to UHF Adapters
- 11) Instruction Manual.

INSTALLATION

Directional Coupler

Locate the Directional Coupler as close as possible to the transmitter RF output connector. Mounting brackets are provided. Make up a SHORT piece of RG-58 Coaxial Cable with a BNC connector, UG-88/U, on one end and the appropriate mating connector for the transmitter on the other end. Keep this cable length as short as possible.

Install a BNC UG-88/U connector on the coaxial antenna line. If your line is large diameter RG-8, this will not be possible. We suggest in this case that the line have a PL-259 connector in conjunction with a UG-255/U in-line UHF to BNC adapter, two of which are furnished.

Indicator Unit

Determine location of Indicator unit in the station. This is not critical as regards distance from the Directional Coupler. Prepare the inter-connecting cable using terminals and lugs supplied. For the cable end at the Directional Coupler, push on terminals and shrink tube insulators are provided. Slide insulation over the stripped wires BEFORE soldering the terminals to the wires. Then push insulating sleeves over the connectors and heat the tubing over a flame or hot plate to a temperature of 250° F. for 10 seconds. The insulator will shrink tightly around the wires and prevent strain breakage of the wires.

The Indicator and Directional Coupler terminals are marked with colors that correspond to the color coded wires in the furnished cable. Connect units together per drawing in Figure 2.

At frequencies and power levels for which this equipment is designed, there is no reason why all in-the-station coaxial lines cannot be made using small diameter RG-58 cable. See Figure 3 which shows limitations and characteristics of coaxial cable.

OPERATION

With an appropriate antenna connected to the transmitter through the Directional Coupler, operate the transmitter in the CW mode, or if on SSB transmitter, in the "tune" position. Select the Forward Power scale range (2000 or 200) nearest to the rated transmitter output. Adjust transmitter tuning and loading in accordance with Manufacturer's instructions. The transmitter output will be indicated on the Forward Scale (left hand movement), and the Reflected Power on the right hand scale. Note both readings and refer to chart, Figure 4, to determine the VSWR value.

An alternate method of determining the VSWR is to use the curve in Figure 5, if it is possible to adjust transmitter output to permit exact forward meter readings of either 1000 or 100 watts.

With a Forward Power level at 100 watts, read the appropriate Reflected Power value, convert it to percent of Forward Power and read VSWR from Figure 5. For further convenience, a dot is located at the 100 watt point on Scale B, and calibration marks on Scale C correspond to specific values of VSWR that are correct at 100 watts Forward Power.

The Model 369A REFLECTOMETER will read transmitter output accurately only if the load of the transmitter is close to unity (1:1) VSWR.

METER SCALES

You will note that the Indicator Unit Meter has 3 scales and two meter pointers. All scales must always be multiplied by 10.

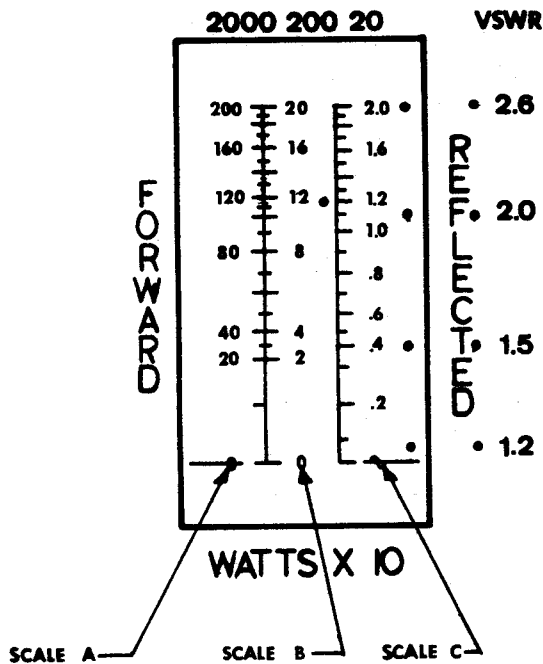

FOR: 2000 watts Forward, read Scale A, left pointer
200 watts Forward, read Scale B, left pointer
2000 watts Reflected, read Scale A, right pointer
200 watts Reflected, read Scale B, right pointer
20 watts Reflected, read Scale C, right pointer

OPERATING HINTS

- 1) The best VSWR measurement possible is 1.06:1 because this is the residual mismatch in the Directional Coupler.
- 2) It will be helpful to make up a chart based on normal Forward Power of your transmitter to obtain quick estimates of VSWR. For example, if your transmitter normally puts out 200 watts (Forward), any on-scale reading on the 20 watt scale (C) indicates a VSWR of less than 2:1.
- 3) When using the REFLECTOMETER to "tune" a mobile antenna, resonance of the antenna can be obtained quickly by tuning the transmitter frequency control dial for minimum Reflected Power, while maintaining (by tuning) a maximum Forward Power.
- 4) Remember that others use frequencies on which you tune up. Do your antenna adjustments at the lowest power levels possible and for the shortest time to avoid needless interference.
- 5) VSWR values marked on Scale C are correct when Forward Power is set at exactly 100 watts (Scale B).
- 6) Care should be exercised to avoid operation at high power levels without a load. Operation of a transmitter without a load imposes infinite VSWR values. A breakdown gap is built-in to the Directional Coupler to minimize damage that may be caused with unloaded operation.

WARRANTY

Standard Electronic Instrument Warranty

Each instrument, or part thereof, sold by Waters Manufacturing, Inc. is warranted to be free from original defects in material and workmanship.

The obligation under this warranty is limited to the repair or replacement of any instrument, or part thereof, except tubes, semi-conductor devices, and batteries, which shall, within the period of six months from the shipment to the original purchaser, prove upon examination by Waters Manufacturing, Inc. to have become defective through normal use or handling, providing further that the original customer has filled out and returned the Warranty Record Card to the manufacturer within 10 days from date of purchase.

While NO CHARGE is made for IN-WARRANTY service, a reasonable charge of \$4.00 will be made to cover costs of handling, re-inspection, re-packing and return shipment to you. When returning a unit to the factory, please include full information as to the nature of the difficulty and enclose check or money order for \$4.00 handling charge with the unit.

OUT-OF-WARRANTY service is also available at the factory at reasonable rates on a time and material basis.

The right is reserved to change the published specifications of equipment at any time, and to furnish merchandise in accordance with current specifications, without incurring any liability to modify equipment previously sold, or to supply new equipment in accordance with earlier specifications.

- NOTES:
1. ALL CAPACITORS ARE IN μf , GMV UNLESS OTHERWISE SPECIFIED.
 2. SWITCH (S_1A & S_1B) SHOWN IN 2000/2000 POSITION, (FULL CCW POSITION).

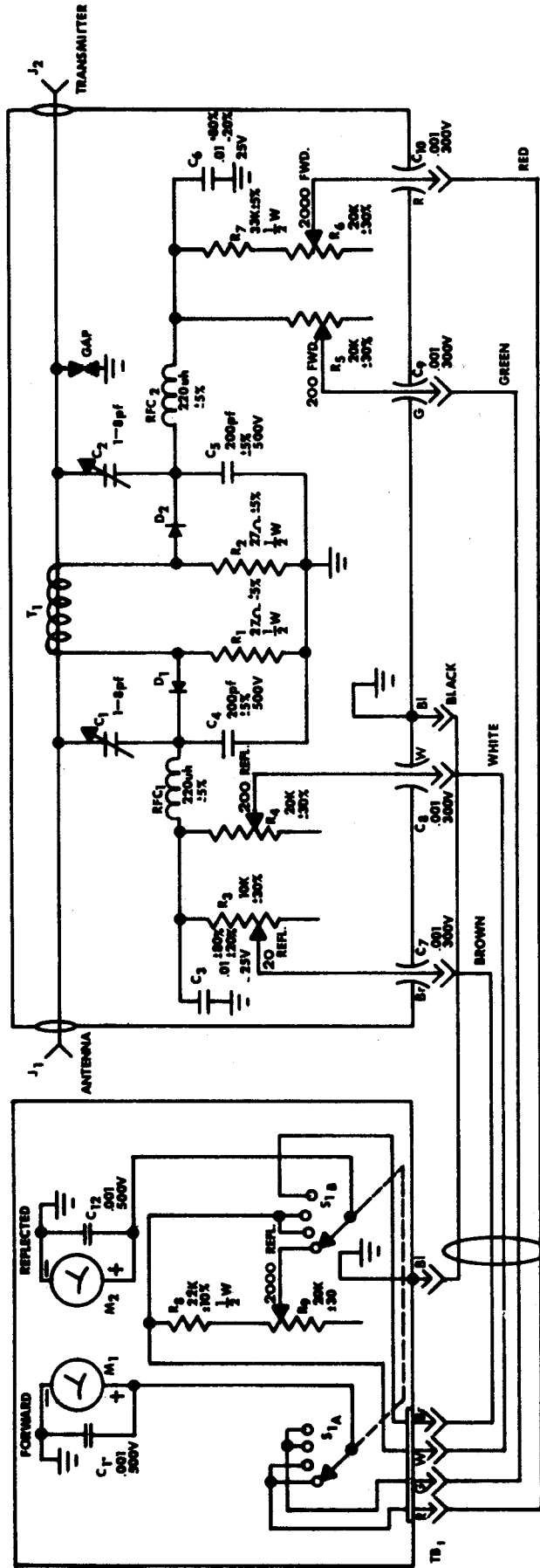

FIG. 1
SCHEMATIC
REFLECTOMETER
MODEL 349A

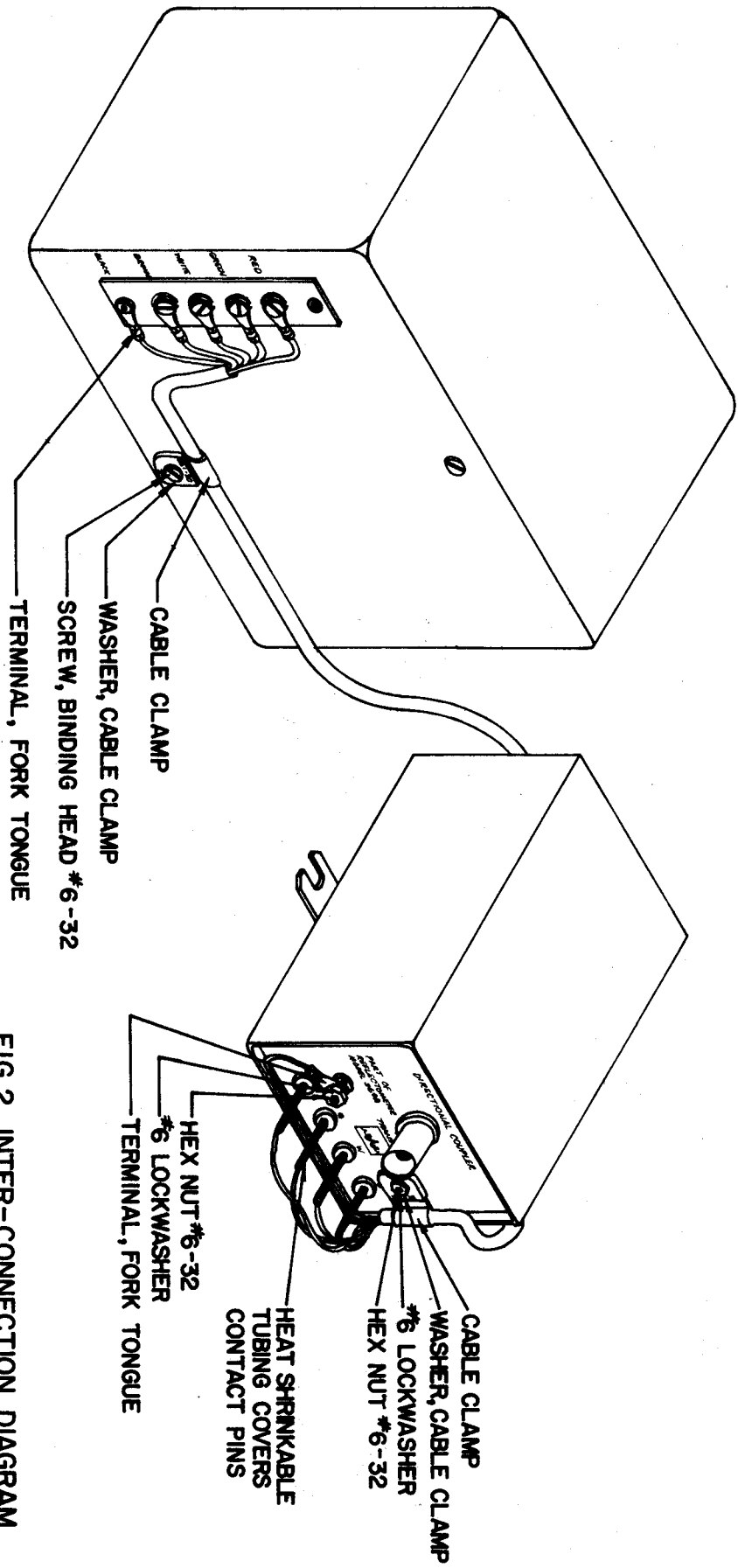
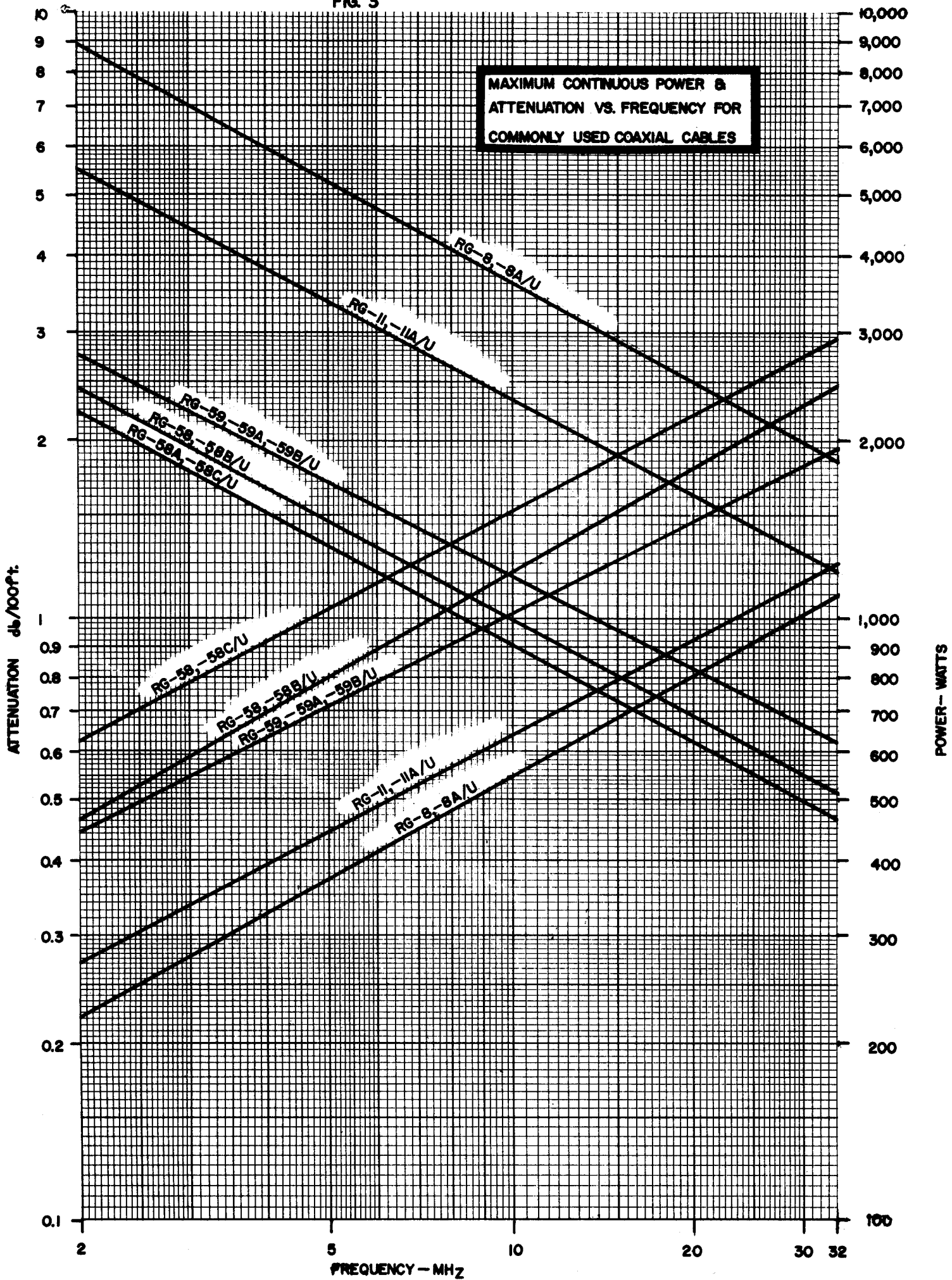

FIG. 2 INTER-CONNECTION DIAGRAM

FIG. 3



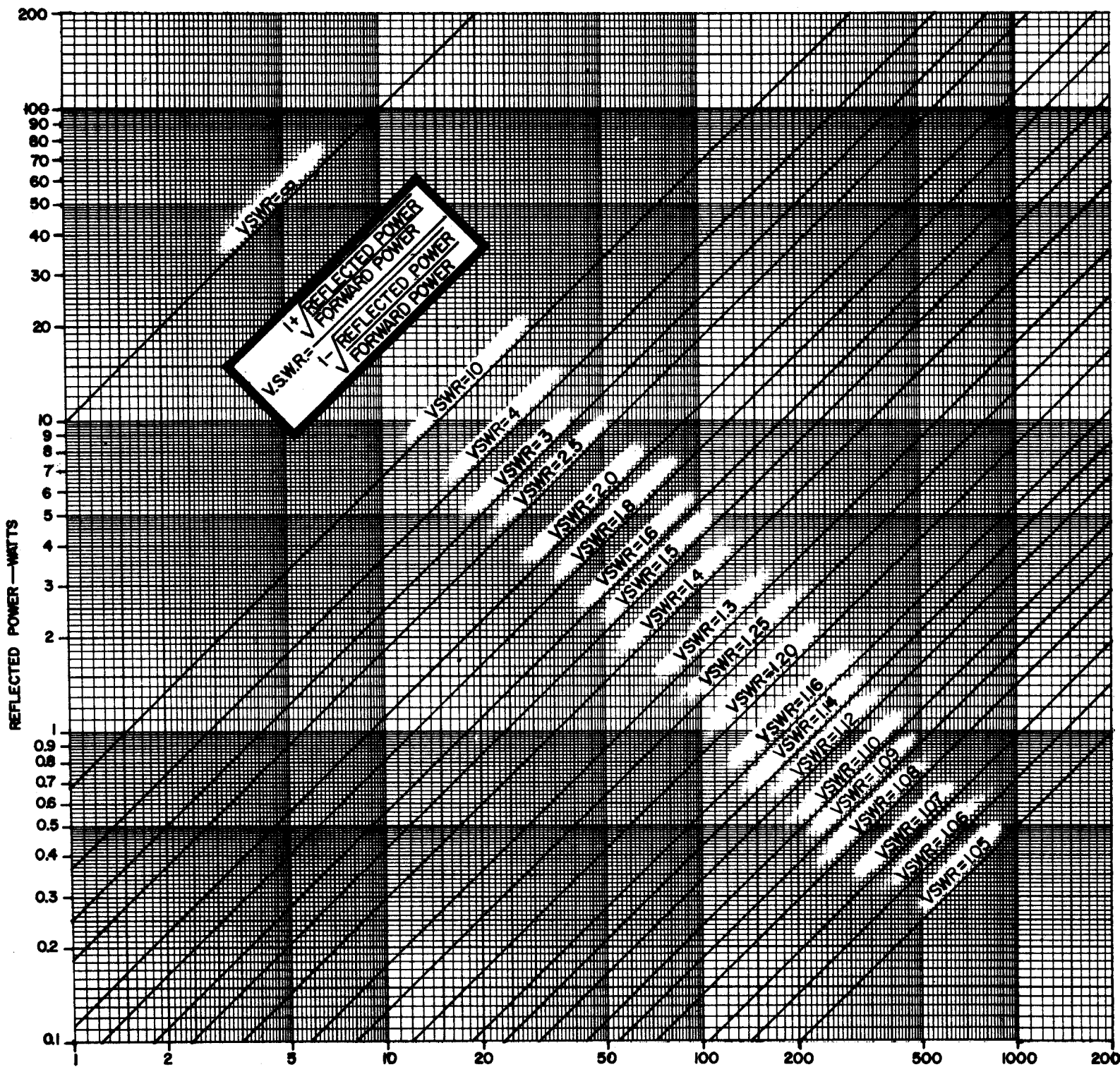

FIG. 4 V.S.W.R. CHART

FIG. 5

